

# HYDRAULIC SCISSOR COMMERCIAL LIFT

*Great performance and the perfect choice  
for your commercial service.*



**AX-12**

**AX-12A**

**AX-16A**

## SPECIFICATIONS

Model		AX-12	AX-12A	AX-16A
Style		Non-Alignment	Alignment	Alignment
Lifting Capacity		12,000lbs (5500kg)	12,000lbs (5500kg)	16,000lbs (7300kg)
Lifting Time		75S	75S	110S
Overall Length (Inc. Ramps)	A	258" (6554mm)	258" (6554mm)	274 1/8" (6964mm)
Overall Length (No Inc. Ramps)	B	197 1/2" (5018mm)	197 1/2" (5018mm)	213 3/4" (5428mm)
Overall Width	C	90 1/8" (2290mm)	90 1/8" (2290mm)	94 1/8" (2390mm)
Lifting Height	D	11 3/4-73 5/8" (300-1870mm)	11 3/4-73 5/8" (300-1870mm)	13"-73 5/8" (330-1870mm)
Runway Width	E	24 5/8" (625mm)	24 5/8" (625mm)	24 5/8" (625mm)
Width Between Runway	F	37 5/8" (955mm)	37 5/8" (955mm)	41 5/8" (1055mm)
Min. Four Wheel Align	G	/	81 7/8" (2080mm)	98" (2490mm)
Max. Four Wheel Align	H	/	167 3/4" (4260mm)	184 1/2" (4680mm)
Max. Two Wheel Align	I	/	174" (4420mm)	190 1/2" (4840mm)
Motor		2.0HP, 220V/60Hz, single phase		
Gross Weight		4,749lbs (2154kg)	5,785lbs (2624kg)	6,345lbs (2878kg)

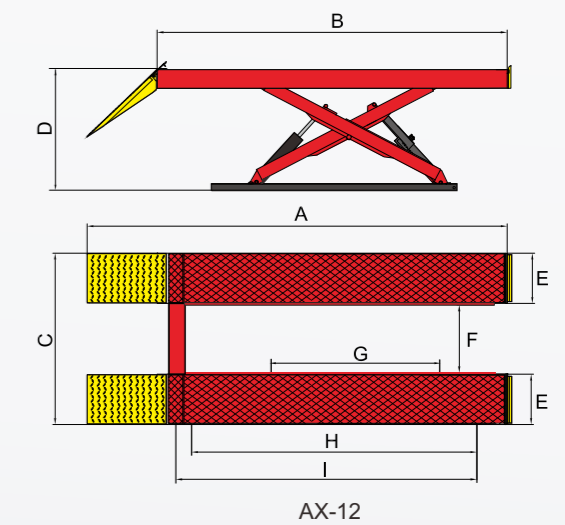
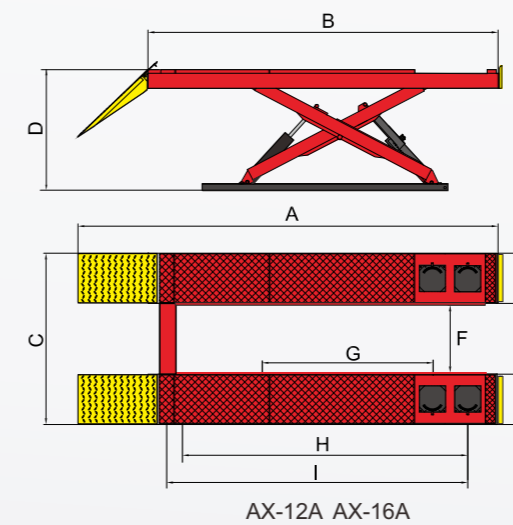

AMGO HYDRAULIC CORPORATION

1931 Joe Rogers Jr Blvd, Manning, SC 29102, USA  
Tel: (803)505-6410 www.amgohyd.com

# HYDRAULIC SCISSOR ALIGNMENT LIFT

*This heavy-duty scissor lift has the support of four cylinders and each dual cylinder are designed to work synchronously.*

- ✓ 2 dual synchronous cylinders are used to assure the optimal lifting level on both platforms.
- ✓ Electronic-air control system, which operates the self-locking safety mechanism.
- ✓ Heavy-duty design, the X serial scissor lift uses a 5 7/8" x 3" (150 x 75mm) tube to make it strong and assures the runways remain level during operation.
- ✓ Skid proof diamond platform provides traction for the tires to stay put.
- ✓ Optional rolling jacks:
  - J6H: 6,000 lbs with manual pump
  - J6A: 6,000 lbs with pneumatic pump
  - RJ-8A: 8,000 lbs with pneumatic pump
- ✓ More choices:
  - Optional turnplate Kits No. 40101 (AX-12A) (AX-16A)
  - Optional led lights Kits No. 40103001
  - Optional extension Kits No. PX001 (AX-12)/PX002 (AX-12A)/PX003(AX-16A)
  - Optional airline Kits No. PX004



## FEATURES



- Mechanical lock and air-driven safety release.



- Pull-out shelf for extra room allows more effective working environments



- Optional LED lights provide extra and efficient lighting for underneath the vehicle.  
Kits No.:40103001

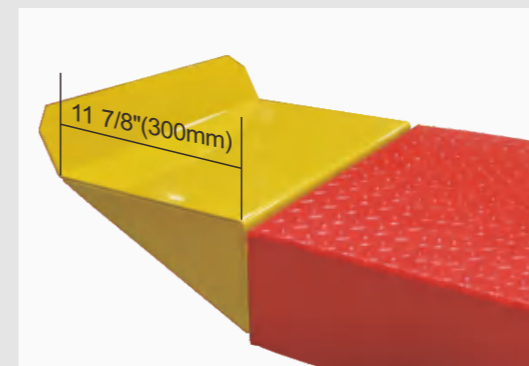

- Optional extension kits to extend the platform 11 7/8" (300mm).  
Kits No.:PX001(AX-12)  
Kits No.:PX002(AX-12A)  
Kits No.:PX003(AX-16A)



- Optional airline kits. Easy and convenient installation for all models of rolling jacks with a pneumatic pump.  
Kits No.:PX004